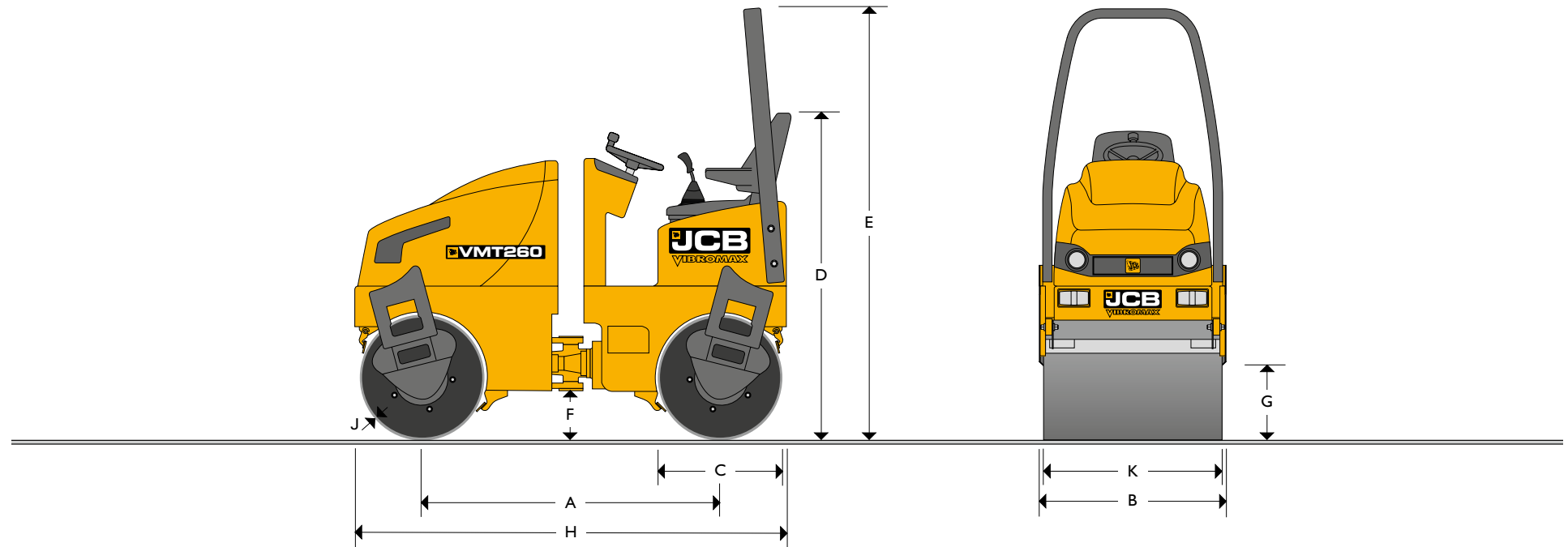

DRUM WIDTH: 1000mm – 1200mm (39.4in – 47.2in) OPERATING WEIGHT: 2600kg – 2700kg (5732lb – 5952lb)

STATIC DIMENSIONS

Dimensions in millimetres (in)	VMT260-100	VMT260-120
A Wheelbase	1700 (66.9)	1700 (66.9)
B Overall width	1080 (42.5)	1280 (50.4)
C Drum diameter	700 (27.5)	700 (27.5)
D Height to top of seat	1760 (69.3)	1760 (69.3)
E Height to top of ROPS	2480 (97.6)	2480 (97.6)
F Ground clearance	270 (10.6)	270 (10.6)
G Curb clearance	550 (21.6)	550 (21.6)
H Total travel length	2490 (98)	2490 (98)
J Drum thickness	12 (0.47)	12 (0.47)
K Drum width	1000 (39.3)	1200 (47.2)

OPERATING DATA

Operating data		VMT260-100	VMT260-120
Operating weight max.	kg	2600	2700
Working width	mm	1000	1200
Operating linear load	kg/cm	13	11.2
Exciter frequency	Hz	50 ... 66	50 ... 66
Nominal amplitude	mm	0.5	0.5
Centrifugal force (each drum)	kN	26 ... 45	26 ... 45
Max. Working speed	km/h	0 ... 11	0 ... 11
Drum offset left / right (Option)	mm	80	80
Steering lock angle	°	±35	±35
Oscillation angle	°	±8	±8
Inner turning radius	mm	2200	2100
Gradeability with vibration up to	° (%)	17 (30)	17 (30)
Gradeability without vibration up to	° (%)	22 (40)	22 (40)

ENGINE

Make	KUBOTA	
Model	D1703M-E3B (EPA Tier IV / EU 3a)	
Type	3 cylinder, water-cooled, four-stroke diesel engine	
Piston displacement	cm ³	1499
Performance	kW (hp)	24.4 (32.7)
Operating speed	min ⁻¹ (rpm)	2800
Starting device	Electric motor	
Air cleaner	Dry cartridge plus safety cartridge	
Fuel filter	Cartridge	
Fuel consumption	l/h	5.0

PROPULSION

Hydrostatic with variable displacement pump and fixed displacement motors with direct drive to both drums = double drum drive.

EXCITER DRIVE

Electrically controlled hydrostatic direct drive on both drums for double vibration or single vibration front or rear.

EXCITER

Single-shaft circular exciter for superior durability.

STEERING SYSTEM

Servo assisted center articulation with oscillation facility.

SERVICE CAPACITIES

Fuel	litres	95
Sprinkler water	litres	230

BRAKING SYSTEM

Service brake: Hydrostatic propulsion system.
Parking brake: Hydraulically released brake on both drums (SAHR).

ELECTRICAL SYSTEM

Working lights, backup alarm, safety switch in operators seat

Voltage	V	12
Battery capacity	Ah	66
Alternator	A	40

DRIVERS STAND/INSTRUMENTS

Fuel, battery charging current, sprinkler system, parking brake, hour meter, engine oil pressure, air filter condition, hydraulic oil level and temperature, water level indicator.

OPTIONS

ROPS (standard at CE), foldable ROPS, lights for road traffic, flashing beacon, battery isolating switch.

